

RICS Practice Standards, UK

# Party wall legislation and procedure

6th edition, guidance note



**RICS**

the mark of  
property  
professionalism  
worldwide

[rics.org/standards](https://www.rics.org/standards)



# Party wall legislation and procedure

RICS guidance note

6th edition (GN 27/2011)

Published by the Royal Institution of Chartered Surveyors (RICS)

Surveyor Court

Westwood Business Park

Coventry CV4 8JE

UK

[www.ricsbooks.com](http://www.ricsbooks.com)

No responsibility for loss or damage caused to any person acting or refraining from action as a result of the material included in this publication can be accepted by the authors or RICS.

Produced by the Land Professional Group of the Royal Institution of Chartered Surveyors.

First published 1982

Second edition 1983

Third edition 1986

Fourth edition 1996

Fifth edition 2002

Reprinted with amends 2002

Reprinted 2006

Reprinted 2007

Revised 5th edition 2007

ISBN 978 1 84219 700 4

© Royal Institution of Chartered Surveyors (RICS) October 2011. Reprint. Copyright in all or part of this publication rests with RICS. No part of this work may be reproduced or used in any form or by any means including graphic, electronic, or mechanical, including photocopying, recording, taping or Web distribution, without the written permission of the Royal Institution of Chartered Surveyors or in line with the rules of an existing license.

Crown copyright material is reproduced with the permission of the Controller of HMSO and the Queen's Printer for Scotland.

Printed in Great Britain by Page Bros, Norwich

# Contents

---

<b>Acknowledgments</b>	<b>vi</b>
<b>RICS guidance notes</b>	<b>1</b>
<b>1 Introduction</b>	<b>2</b>
<b>2 Nature and purpose of the <i>Party Wall etc. Act 1996</i></b>	<b>3</b>
2.1 Construction work close to boundaries	3
2.2 Historical context	3
2.3 Effect on common law rights	3
2.4 Unnecessary inconvenience	3
2.5 Definitions	4
<b>3 Advising clients on the application of the Act</b>	<b>6</b>
3.1 Surveyors' responsibilities to clients	6
3.2 Line of junction works	6
3.3 Works to party walls (and certain other boundary structures)	6
3.4 Adjacent excavation works	7
3.5 Access to an adjoining owner's land	7
<b>4 Services of notices</b>	<b>9</b>
4.1 The importance of valid service	9
4.2 Content of notices	9
4.3 Methods of service	10
4.4 Responses to notices	10
4.4.1 The adjoining owner does nothing	10
4.4.2 The adjoining owner agrees to the works as proposed	10
4.4.3 The adjoining owner dissents from the works proposed	11
4.5 Service of counter-notices	11
<b>5 Accepting appointments under the Act</b>	<b>12</b>
5.1 Letters of appointment	12
5.2 Who may act as surveyor	12
5.3 Status of a party-appointed surveyor	12
5.4 Appointment as agreed surveyor	13
5.5 Professional conduct issues	13
5.6 RICS Regulation issues	13

<b>6</b>	<b>Powers and duties of appointed surveyor</b>	<b>15</b>
6.1	Statutory purpose of surveyors' role	15
6.2	Surveyors' duties	15
6.3	Surveyors' jurisdiction	15
	6.3.1 Proper constitution of the surveyor's tribunal	15
	6.3.2 Competence of the surveyors' tribunal	15
	6.3.3 Authority of the surveyors	16
6.4	Enforcement of surveyors' awards	16
<b>7</b>	<b>Surveyors' role in preparing primary award</b>	<b>17</b>
7.1	Preparing schedules of condition	17
7.2	Agreeing the contents of the award	17
7.3	Provision for disturbance, making good and compensation	17
7.4	Expenses of the works	18
7.5	Costs of the award (including surveyor fees)	18
	7.5.1 Surveyor fees	18
	7.5.2 Advising engineer fees	19
	7.5.3 Other consultant fees	19
7.6	Signature and service of awards	19
7.7	Entry onto adjoining land	19
7.8	Security for expenses	20
<b>8</b>	<b>Surveyors' role subsequent to publication of primary award</b>	<b>22</b>
8.1	Interim and final inspections	22
8.2	Design changes	22
8.3	Where additional work becomes necessary	22
8.4	Awarding compensation and making good	22
8.5	Changes of ownership	23
<b>9</b>	<b>Role of the third surveyor</b>	<b>24</b>
9.1	Nature of the role	24
9.2	Preliminary notification	24
9.3	Referral to the third surveyor	24
9.4	Procedure on referral to the third surveyor	24
9.5	Third surveyor's award	25
<b>10</b>	<b>Challenging the award and appeals to the county court</b>	<b>26</b>
10.1	Challenging the award	26
10.2	Appeals to the county court	26

<b>Appendices</b>		<b>27</b>
A	Draft letters	27
	1 Surveyor's statutory appointment and authority	29
	2 To accompany a typical section 3 or 6 notice	30
	3 Requiring an adjoining owner to appoint a surveyor	31
	4 Requiring an appointed surveyor to act effectively	32
	5 To appointing owners upon service of the party wall award	33
	6 Draft solicitor's or chartered surveyor's undertaking for holding security monies	34
B	Draft notices	35
	1 Line of junction notice: <i>Party Wall etc. Act</i> 1996, section 1	37
	2 Acknowledgment of line of junction notice	38
	3 Party structure notice	39
	4 Acknowledgment of party structure notice	40
	5 Notice of adjacent excavation	41
	6 Acknowledgment of notice of adjacent excavation	42
C	Specimen schedule of condition	43
D	Draft award	49
<b>Further reading</b>		<b>55</b>

---



# Acknowledgments

---

The RICS Boundaries and Party Walls Panel (B&PWP) is a cross-Professional Group specialist panel of associate and chartered surveyors from the building, land surveying (geomatics) and rural areas of practice. It brings together some of the foremost and distinguished professional surveyors working within the arena of neighbour disputes. Its remit includes boundaries, party walls and certain easements, such as rights of way and rights of light. These issues lie at the core of many RICS members' professional work.

The B&PWP also produces RICS professional guidance and information, public guides, client guides, policy responses and journal articles. It was involved in the inception of RICS Dispute Resolution Service (DRS) Neighbour Dispute Service and has been taking part in its ongoing operation. The B&PWP exists to promote understanding and best practice in the areas of neighbour disputes such as party walls, land transfer, registration and administration, encroachments, cadastre and boundary issues, and/or to an improvement in the administration of the laws regarding them within the United Kingdom and overseas.

B&PWP publications can be found at the following web addresses: [www.rics.org/land](http://www.rics.org/land) and [www.rics.org/mappp](http://www.rics.org/mappp).

## B&PWP membership

---

### Panel Chair

John Lytton FRICS – John Lytton & Co Ltd

### Members

Robin Ainsworth FRICS – Ainsworth Surveying Services Ltd

Andrew D Thompson FRICS – Neighbourly Matters

David J Powell FRICS – David J Powell Surveys Ltd

Carl Calvert FRICS – Calvert Consulting

Alistair Redler FRICS – Delva Patman Associates

Graham North FRICS – Anstey Horne & Co Ltd

Jon Maynard FRICS – Jon Maynard Boundaries Ltd

Mark Behan MRICS – Behan Partnership LLP

Peter Lord AssocRICS – Land Registry

Nigel Atkinson FRICS – Morton Atkinson Associates

James Kavanagh MRICS – RICS

### Working group

In order to produce this guidance the following subgroup of the panel was formed, and its members' time and assistance are acknowledged:

Robin Ainsworth, FRICS – Ainsworth Surveying Services Ltd

Michael Cooper, MRICS – Savills Commercial

Alistair Redler FRICS – Delva Patman Associates

Graham North FRICS – Anstey Horne & Co Ltd

Andrew D Thompson FRICS – Neighbourly Matters

Mark Behan MRICS – Behan Partnership LLP

Andrew Smith – Solicitor, Child & Child

Howard Smith – Barrister, Radcliffe Chambers

RICS also wishes to acknowledge the help and assistance of the many consultees.

# RICS guidance notes

---

**This is a guidance note. It provides advice to RICS members on aspects of their work. Where procedures are recommended for specific professional tasks, these are intended to represent 'best practice', i.e. procedures which in the opinion of RICS meet a high standard of professional competence.**

Although members are not required to follow the advice and recommendations contained in the note, they should note the following points.

When an allegation of professional negligence is made against a surveyor, a court or tribunal is likely to take account of the contents of any relevant guidance notes published by RICS in deciding whether or not the member had acted with reasonable competence.

In the opinion of RICS, a member conforming to the practices recommended in this note should have at least a partial defence to an allegation of negligence if they have followed those practices. However, members have the responsibility of deciding when it is inappropriate to follow the guidance.

Alternatively, it does not follow that members will be found negligent if they have not followed the practices recommended in this note. It is for each surveyor to decide on the appropriate procedure to follow in any professional task. However, where members do not comply with the practice recommended in this note, they should do so only for a good reason. In the event of a legal dispute, a court or tribunal may require them to explain why they decided not to adopt the recommended practice. Also, if members have not followed this guidance, and their actions are questioned in an RICS disciplinary case, they will be asked to explain the actions they did take and this may be taken into account by the Panel.

In addition, guidance notes are relevant to professional competence in that each member should be up to date and should have knowledge of guidance notes within a reasonable time of their coming into effect.





# 1 Introduction

---

This guidance note replaces *Party Wall Legislation and Procedure*, revised 5th edition (2007). It provides guidance for RICS members who accept instructions for which the *Party Wall etc. Act* 1996 may be relevant. It also describes the circumstances in which the Act will apply, as well as the procedures to be followed where it does.

The role of surveyors when acting for a client in the early stages of these procedures is addressed, as is the duty of surveyors who are formally appointed to administer the Act's dispute resolution mechanism. It assumes that those accepting such appointments possess the necessary knowledge

and professional competence to do so, as guidance on that matter is outside the scope of this publication. This guidance note deals only with matters connected with the Act, and members are thus advised that other legal, regulatory and practical considerations may also be relevant in particular instances of construction work close to a boundary.

The role of a party wall surveyor is a statutory one and one that is independent of instructions from an appointing party. However, the surveyor acting in this role must comply with the RICS Rules of Conduct insofar as they do not conflict with the provisions of the Act.

# 2 Nature and purpose of the *Party Wall etc. Act 1996*

---

## 2.1 Construction work close to boundaries

---

Despite its title, the *Party Wall etc. Act 1996* is not concerned solely with party walls (as defined in paragraph 2.5(c)). It also regulates the relationship between neighbouring owners concerning specified types of construction work on, or in close proximity to, the boundary between adjoining properties. These types of construction work will often involve a party wall, although not in every case.

Members should be particularly mindful of the fact that work undertaken wholly on the land of a single owner may nevertheless be subject to the requirements of the Act. For example, excavations at particular depths and within certain distances of adjoining buildings are regulated, even where no party wall is present. Furthermore, the Act also regulates work to certain types of structure situated entirely on the land of one of two neighbouring owners, in addition to work affecting party walls.

## 2.2 Historical context

---

The relationship between neighbouring owners during construction operations is governed primarily by common law. In particular, the law of tort limits the extent to which a landowner can undertake construction works that either directly or indirectly impinge on adjoining land.

In some cities within England these common law rules have historically been varied in certain respects by the existence of local statutory codes. The most significant of these was the London code, whose history can be traced back to a 1667 Act following the Great Fire of London. The code first appeared substantially in its modern form in Part III of the *Metropolitan Building Act 1855* and, most recently, in Part VI of the *London Building Acts (Amendment) Act 1939*.

Effective from 1 July 1997, the broad effect of the *Party Wall etc. Act 1996* is to extend the provisions of the London code to all of England and Wales.

The only exceptions are Crown properties occupied by the Royal Family and the London Inns of Court. Common law rules regulating the rights of neighbouring owners have to be read in the context of the procedural requirements contained within the code.

When interpreting the code contained within the 1996 Act, members should have regard to the cases decided under earlier enactments containing the London code, and any change to the wording of the relevant statute.

## 2.3 Effect on common law rights

---

The purpose of the 1996 Act is to facilitate construction operations in the vicinity of boundaries. It achieves this partly by providing a procedural framework that ensures neighbouring owners are notified of impending construction works.

In addition, the Act entitles property owners to interfere with the land and structures belonging to neighbouring owners. The Act provides statutory authority to perform acts which would otherwise constitute the tort of trespass or nuisance, provided that the procedures under the Act are followed. The demolition and rebuilding of a party wall, the cutting in of a flashing into a neighbour's wall and the entry onto a neighbour's land to perform other works in pursuance of the Act are all examples of the types of intrusive operation that are authorised.

Although sanctioned by the Act and subject to the service of formal notice or written agreement, these rights must not be exercised in a way in which unnecessary inconvenience is caused to adjoining owners or occupiers (see paragraph 2.4).

## 2.4 Unnecessary inconvenience

---

The Act authorises work that may involve physical encroachment onto a neighbour's land, or produce dust, vibration, noise or some other inconvenience or annoyance, but it must be carried out in such way so as not to cause unnecessary inconvenience. If

this is caused, it would be unlawful and actionable by adjoining owners or occupiers.

The appointed surveyors are central to this process of regulation. Their primary role is to balance the interests of the two appointing parties and not to frustrate the statutory process. They are also tasked to ensure that the building owner is able to exercise his or her rights under the Act, but in such a way that only necessary inconvenience is caused to adjoining owners or occupiers. This is achieved by the surveyors defining, in an award, the detail of the work which may be lawfully carried out under the Act and reasonable inspections of work to which an award relates.

The remainder of this guidance note provides surveyors with further details about the nature of this statutory role and the requirements of the statutory code.

## 2.5 Definitions

Sections 20–22 of the Act contain the relevant statutory definitions and interpretation provisions. Attention is drawn, in particular, to the following:

a) The **geographical area** covered by the Act is England and Wales.

- b) An **owner** is defined, in simple terms, as someone with more than a yearly tenancy. There may be more than one ‘owner’ of an adjoining property, for example a freeholder, long leaseholder and occupying tenant, or someone with an agreement to purchase or lease.
- c) A **party wall** has two definitions in section 20: it can be either (a) a wall standing on the land of two owners to a greater extent than simply projecting foundations (Figure 1), or (b) the part of a wall standing on the land of one owner that separates the buildings of two owners (Figure 2). In case (b), Mr Black could have, at some time in the past, constructed a building using some part of the external wall of Mr Jones’ building to enclose his own building. The ownership of the wall remains with Mr Jones, but wherever Mr Black’s building is up against it, that part has become a party wall (shaded area).
- d) A **party structure** can be a party wall, a floor or a partition separating different parts of a building each with separate entrances (Figure 3).
- e) A **party fence wall** is a free-standing wall that is not part of a building and stands astride a boundary (Figure 4).

Figure 1: Type (a) party walls

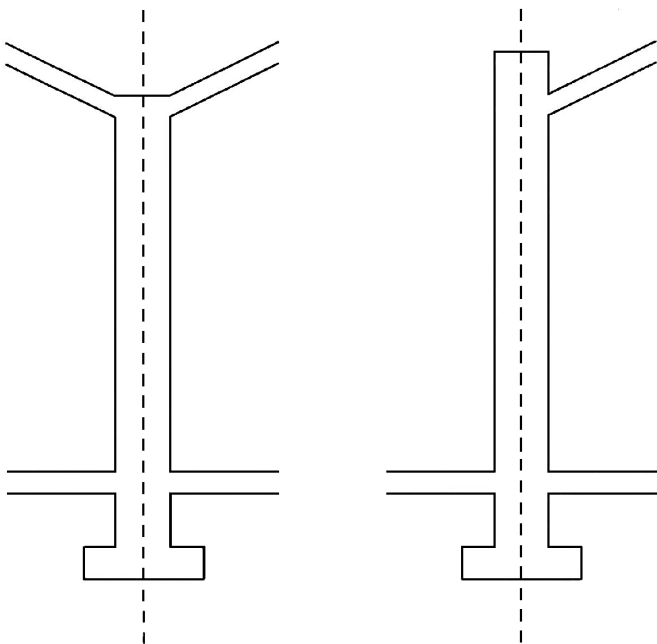
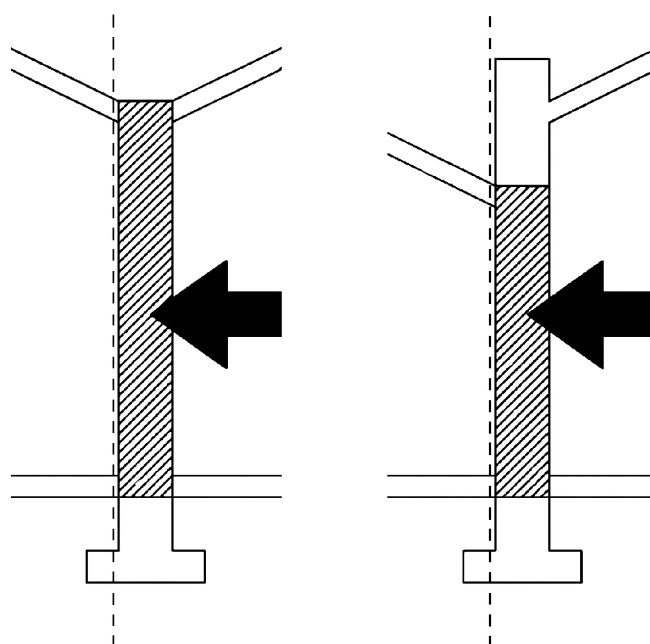
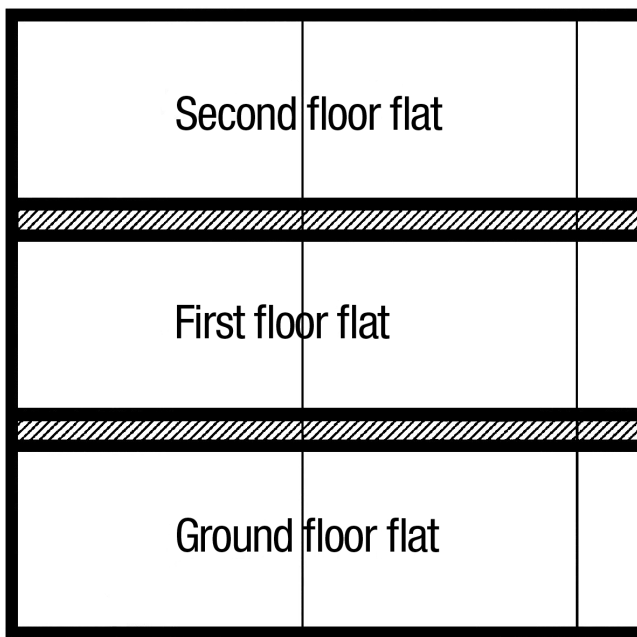

Figure 2: Type (b) party walls



**Figure 3: Party structures**



- f) The person (or company) who initiates any work on his or her side of a wall is described as the **building owner**. The owner(s) on the other side is (are) each an **adjoining owner**.
- g) **Special foundations** are those in which an assemblage of beams or rods is employed for the purpose of distributing any load.

Whilst not defined, the Act also uses the following expressions:

- An **external wall** is a wall that forms part of a building standing wholly on the land of one owner and which may be situated at, but not astride, a boundary (except to the extent of any projecting footing or foundation) (Figure 5).
- A **boundary wall** is a freestanding wall, not being part of any building, which stands wholly on the land of one owner at, but not astride, a boundary (except to the extent of any projecting footing or foundation) (Figure 6).

**Figure 4: Party fence wall**

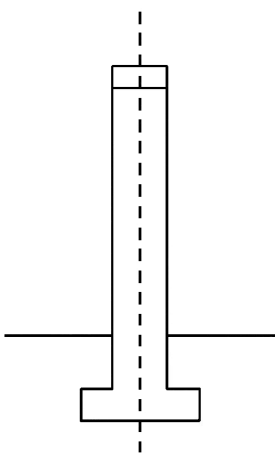

**Figure 5: External wall**

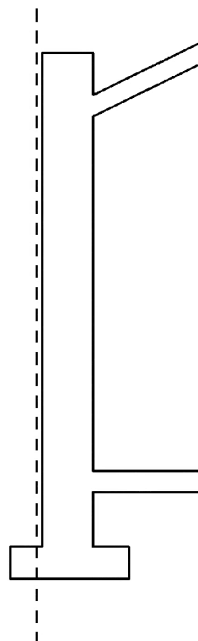

**Figure 6: Boundary wall**

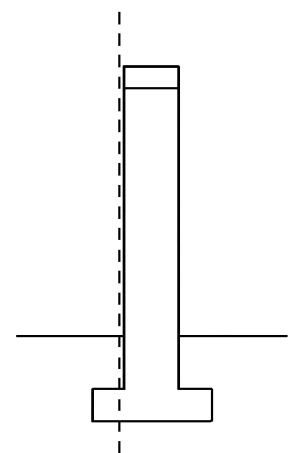

# 3 Advising clients on the application of the Act

---

## 3.1 Surveyors' responsibilities to clients

---

Surveyors are often asked to advise whether the Act applies to specific building operations. They should be familiar with the circumstances in which the Act applies and should be able to advise whether service of notices will be required in particular situations.

When advising in this context, surveyors are acting in the capacity of professional consultants and owe duties to their clients on this basis. This capacity may later change to that of an 'appointed surveyor' once notices have been served and a dispute has arisen under the Act (see chapter 5). At every stage of their involvement with party wall work, surveyors should be clear about the capacity in which they are currently acting and to whom their professional duties are owed.

The Act regulates construction operations in three distinct situations: line of junction works; works to party walls (and certain other boundary structures); and adjacent excavation works. Surveyors should be familiar with all of these, which are described in the following paragraphs.

## 3.2 Line of junction works

---

Line of junction works occur where nothing is built on a boundary line (line of junction) or where the only structure built is a free-standing boundary wall that does not straddle the boundary line (see the precise wording in section 1(1) of the Act). The presence of a fence alone means that the boundary line is not 'built on' within the meaning of the Act.

In such situations, a building owner is required to serve a 'line of junction notice', where the construction of one of the following structures along the line of junction is being proposed (see section 20 of the Act for definitions of the following terms):

- a party wall;
- a party fence wall; or
- a boundary or external wall on the building owner's own land up to the line of boundary.

Where the construction of a party wall or party fence wall astride the boundary line is being proposed, the building owner must serve notice under section 1(2) and the express consent of the adjoining owner must be obtained. If that consent is not forthcoming, the wall must be built entirely on the building owner's land and at his or her own expense. However, projecting footings may be placed onto the land of the adjoining owner providing these are not 'special foundations', which are defined in section 20 of the Act (see paragraph 2.5) and include reinforced concrete foundations. In these circumstances further notice is not required under section 1(5).

Where the building owner wishes to build a wall directly along his or her side of the line of junction, section 1(5) requires notice to be served. In this case, the building owner will again have a right to place footings across the boundary, under the land of the adjoining owner, as long as they are not special foundations. In either of the aforementioned situations the building owner can only place special foundations on the land of an adjoining owner with the adjoining owner's express consent in writing.

Where a line of junction notice is required, it must be served by the building owner on any adjoining owner at least one month before the intended start date for the works. The notice should describe the intended wall, state whether the building owner plans to lay projecting foundations on the adjoining owner's land and should give details of any access requirements.

## 3.3 Works to party walls (and certain other boundary structures)

---

Section 2 of the Act grants rights to undertake specific work to certain types of boundary structures. The boundary structures involved are generally jointly owned by the building owner and adjoining owner (party walls, party fence walls and party structures). However, in some circumstances, rights are also granted in respect of structures abutting the boundary line but situated entirely on adjoining land, or new structures entirely on the building owner's land adjacent to a party wall.



Surveyors should examine the precise wording of section 2(2) to determine the extent to which the Act applies to the particular structures under consideration. They should not assume that the Act does not apply simply because there is no party wall. This section must also be scrutinised to clarify whether there is a right to undertake the particular type of work being proposed to the structure. Although there will not be a right to undertake all the stated categories of work to every structure type, the rights granted include the following operations:

- underpinning;
- thickening;
- raising;
- repairing;
- demolishing and rebuilding;
- rebuilding;
- cutting into;
- cutting away/cutting off projections;
- reducing height of; and
- exposing.

When seeking to exercise any of the rights in section 2, the building owner must usually first serve a party structure notice on the adjoining owner (see section 3(3) for the limited circumstances when this is not required). Notice must be served at least two months before the intended start date for the works.

As before, there is no right to place special foundations on the adjoining owner's land without the adjoining owner's written permission. This would include, for example, a reinforced concrete foundation to a rebuilt party wall.

### 3.4 Adjacent excavation works

---

The Act not only regulates works to boundary structures, but it also provides protection for

buildings where their stability may be threatened by excavations on adjacent land. Before undertaking excavations falling within the scope of the Act, a building owner is required to serve a notice of adjacent excavation on the relevant adjoining owner(s).

The building owner then has a right to undertake certain work on the adjoining owner's land 'to underpin or otherwise strengthen or safeguard' the foundations of adjacent buildings or structures. Where requested by an adjoining owner, the building owner is required to do this at his or her own expense as far as may be necessary.

The following types of excavations fall within the scope of the Act:

- under section 6(1), excavations within 3m of a building or structure to a lower level than the bottom of the foundations of such building or structure (Figure 7); and
- under section 6(2), excavations within 6m of a building or structure that will cut a line drawn downwards at 45° from the bottom of the existing foundation from a point in line with the outside face of such building or structure (Figure 8).

Similar to the line of junction works (see paragraph 3.2), the building owner must serve notice of such adjacent excavations on any adjoining owner at least one month before the intended start date for the works. Once again, there is no right to place special foundations on the adjoining owner's land without written permission.

### 3.5 Access to an adjoining owner's land

---

Under section 8 of the Act, a building owner has a right of access to the adjoining owner's land for the purpose of executing work in pursuance of the Act (see paragraph 7.7).

**Figure 7: Section 6(1) excavations**

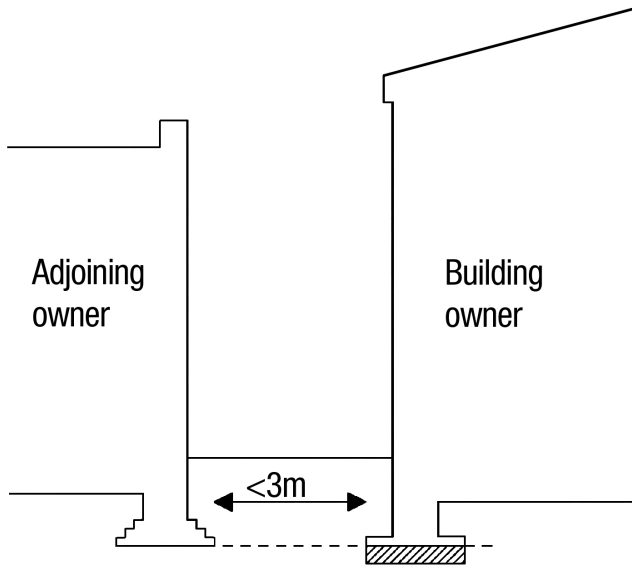

**Figure 8: Section 6(2) excavations**

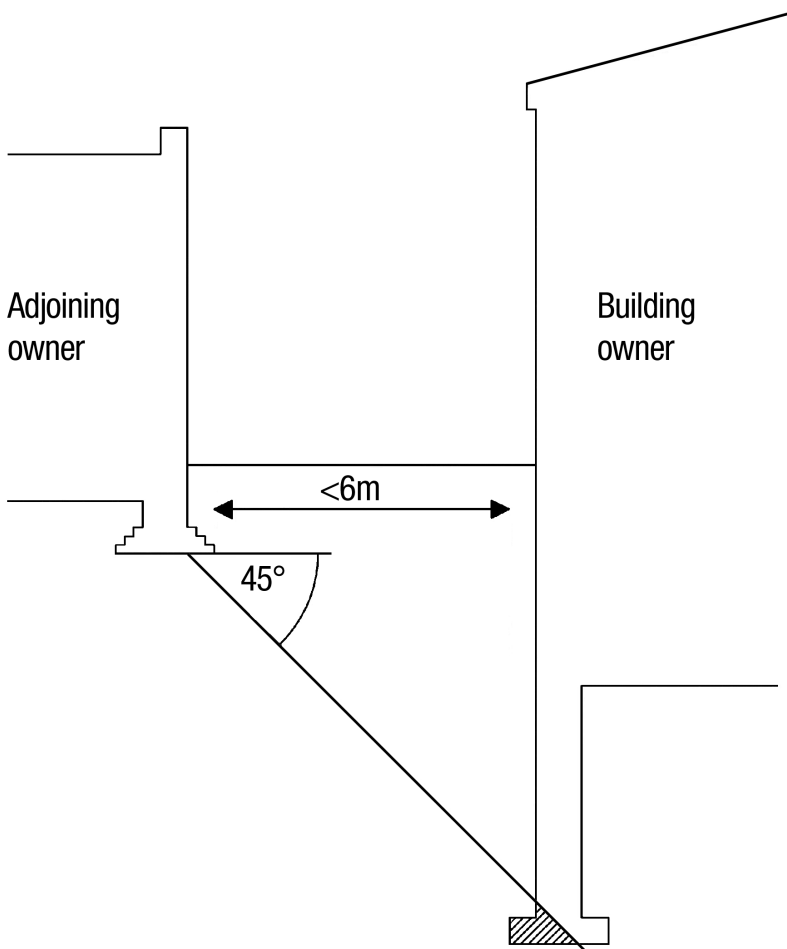

# 4 Service of notices

---

## 4.1 The importance of valid service

---

Service of primary notices (as required by sections 1, 3 and 6 of the Act) commences a statutory procedure. Any deficiency in service may render the whole procedure invalid (see chapter 6). The resulting delay to the project, with consequent increase in costs, may be considerable. Where surveyors are responsible for the preparation and service of notices, they should be aware of related professional liability issues.

It is particularly important for surveyors to comply with the strict time limits stated in the Act for service of notices. They give adjoining owners time to consider the impact of the proposals and enable counter-notices, queries and ultimately disputes to be dealt with properly. These time limits may not be overridden other than by agreement between the owners. Therefore the building owner must be advised as to the minimum notice periods and that the time to complete awards may be longer than the statutory notice periods.

## 4.2 Content of notices

---

Any notice should give sufficient detail and description for the adjoining owner to assess the impact of the proposals on the relevant building. Failure to provide this may invalidate the notice. The notice may be accompanied by drawings, although these are mandatory for section 6 notices. In any event, the notice being served should always comply with the Act's specific requirements, and surveyors should make reference to the Act in this respect.

All notices are required to be served by building owners, but they can authorise surveyors, acting as their agents, to sign and serve notice on their behalf. Beforehand, surveyors should ensure that they have the necessary written authority to do this. It will often be appropriate to use the form of surveyor's statutory appointment and authority provided in Appendix A of this guidance note. This appendix also deals with the formal appointment

of surveyors under the Act, but the forms do not, in themselves, satisfy the RICS requirements for the appointment of a chartered surveyor.

All notices should:

- be in writing;
- give the name and address of the building owner – if owned in joint names, all joint owners must be named;
- be signed – signature should be by the owner, or a person fully authorised to sign notices on the owner's behalf;
- be dated – the date on the notice should be the one on which it is delivered in person, posted to the recipient owner or delivered to the adjacent premises;
- be properly served on all adjoining owners as defined by the Act, whether freehold or leasehold – if an adjoining property is owned in joint names, it has been held that it is only strictly necessary to serve the notice on one of them, however, it is good practice to effect service of a copy of the notice on all joint owners whose identities and addresses are known;
- state the nature and particulars of the intended works and the date on which it is intended to commence the works – descriptions of intended works should be directed toward a layperson and contain sufficient detail to enable the extent of works to be understood;
- where served under section 6, be accompanied by plans and sections showing the site and depth of any excavation and the site of any new building, and state whether the building owner intends to underpin, or otherwise strengthen, or safeguard the foundations of the adjoining owner's building – it is good practice to identify the location of the adjoining owner's building on the drawings;
- where served under section 3 and involving special foundations, be accompanied by drawings showing the special foundation details and reasonable particulars of the loads to be carried; and

- advise the adjoining owner of other issues that may cause statutorily relevant concerns so as to avoid statutory disputes arising at a critical time of the project – for example access, projecting foundations, scaffolding, etc.

There is no proscribed format for the required notices however specimen notices and acknowledgement forms are shown in Appendix B.

### 4.3 Methods of service

---

It is recommended that service of notices be by one of the methods specified in Section 15 of the Act. Section 15 provides that notices may be served on an individual in person, or by posting it to his or her usual or last-known residence or place of business in the UK. In the case of a body, corporate service can be effected by delivering it in person or posting it to the secretary or the clerk at the registered or principal office.

Any notice (or other document) may alternatively be served on an owner by addressing it to ‘the Owner’ of the premises (naming the premises) and delivering (not posting) it to a person on the premises. If no person to whom it can be delivered is found there, the notice may be affixed to a conspicuous part of the premises (but not put through the letter box).

It is prudent that a time allowance should be made for postal delivery of both the notice and an acknowledgment or counter-notice.

### 4.4 Responses to notices

---

When notice is received, the adjoining owner can do one of three things: do nothing; agree to the works as proposed; or dissent to the works as proposed. The proceedings for each of these choices are covered in the following paragraphs.

#### 4.4.1 *The adjoining owner does nothing*

For party structure notices and notices of adjacent excavation, the adjoining owner’s failure to respond within 14 days of service of notice will result in a deemed dispute. The section 10 statutory dispute resolution process then commences.

It may be necessary to serve a request on the adjoining owner to appoint a surveyor within

ten days. If the adjoining owner fails to appoint a surveyor as requested, or refuses to make an appointment, the building owner can appoint a surveyor on behalf of the adjoining owner under the provisions of section 10(4). In either circumstance, it is not possible to appoint an agreed surveyor.

In the case of line of junction notices served under section 1(2), if the adjoining owner fails to respond within 14 days the building owner may only build the proposed wall entirely on his or her own land, but can proceed as soon as the notice period has elapsed. As mentioned in paragraph 3.2, the building owner may also place necessary projecting footings on the adjoining owner’s land providing they are not special foundations (as defined in paragraph 2.5(g)).

Where line of junction notices are served under section 1(5), the adjoining owner’s failure to respond allows the building owner to proceed with the proposed works after the notice period has elapsed. Again, this includes the right to place necessary projecting footings on the adjoining owner’s land, providing they are not special foundations.

#### 4.4.2 *The adjoining owner agrees to the works as proposed*

The adjoining owner may express consent in writing to the works as proposed in the notices. This should not be considered as a waiver of the adjoining owner’s rights under the Act, but simply a statement that, at present, there is nothing in dispute.

Nevertheless, granting unconditional consent to the building owner to undertake the works leaves an adjoining owner with less protection than would be available if consent had not been given. The surveyor should therefore advise of the need to state the terms on which any consent is granted and the desirability or requirement of recording the current state of the adjoining owner’s premises in a schedule of condition.

Consents should contain an express statement that they are not intended to waive the adjoining owner’s rights under the Act and that disputes which subsequently arise in connection with the works are to be resolved in accordance with the section 10 procedures.

### 4.4.3 *The adjoining owner dissents from the works proposed*

If the adjoining owner dissents from any notice served, then the dispute must be settled in accordance with section 10 of the Act. Each owner may agree to the selection of one surveyor (the agreed surveyor) who will determine the matters in dispute. Alternatively, each party may appoint a surveyor and those two surveyors will select a third surveyor. Two of the three surveyors will then determine the matters in dispute. Either of the appointed surveyors, or either of the owners, may call upon the third surveyor to determine matters on which they cannot agree (see chapter 9).

Section 10 allows the surveyors to determine any matters connected with any work to which the Act relates and are in dispute. These include the right to execute the works, the time and manner of execution of the works and any other matter arising out of, or incidental to, the dispute.

As there is no deemed dispute procedure in respect of section 1 works, where a notice under

section 1(5) is being dissented the adjoining owner must specify the nature of its objection(s). This should be on issue(s) within the statutory jurisdiction of surveyors under the Act. The full extent of the dispute should be given upon which subsequently appointed or selected surveyors can determine.

## 4.5 **Service of counter-notices**

---

Following receipt of a notice for works under section 2 of the Act, the adjoining owner may serve a counter-notice within one month setting out such limited additional works as defined in the Act to the party structure or to special foundations as may reasonably be required. It must be accompanied by plans, sections and particulars of that work.

The building owner must comply with the request unless to do so would be injurious, or cause unnecessary inconvenience or unnecessary delay to the works. The costs of the work will be apportioned according to the benefit to either party.



# 5 Accepting appointments under the Act

---

## 5.1 Letters of appointment

---

The appointment of a surveyor arises out of a dispute between the two owners, usually following service of notice. A dispute arises when there is an express dissent to a notice, or one is deemed to arise when the adjoining owner does not respond to a party structure notice or notice of adjacent excavation within 14 days. An actual dispute may also occur in respect of work to which the Act relates, but where no notice has been given.

In any of these situations the parties must then appoint surveyor(s) as described in paragraph 4.4.3. Appointment(s) must be made in writing and directly to the individual surveyor appointed, rather than made in the name of the surveyor's firm. (See the surveyor's statutory appointment and authority in Appendix A for an appropriate form of appointment.)

It is important to note the distinction between an appointment as a party wall surveyor and an authorisation to act as an agent. In each case, however, the surveyor should make the necessary arrangements with the appointing owner in respect of terms of engagement and payment of fees. The courts have ruled a party wall surveyor's fees are a contractual liability of the owner appointing the surveyor.

An appointment must be signed by the owner of the relevant property, or an agent specifically authorised in writing to make such appointment. In the latter case it is good practice to request a copy of the agent's authority. Where property is held in joint ownership, for example a house owned by both a husband and wife, the appointment must be signed by, or on behalf of, all relevant parties.

If an appointment is invalid, then a subsequent award may also be invalid (see chapter 6). Therefore, appointed surveyors are recommended to provide each other with copies of their written appointment before proceeding with any work to negotiate an award.

The selection of a third surveyor should be made by exchange of letters between the appointed surveyors, though it is not necessary for a letter

of selection to be sent to the third surveyor at this stage. It is good practice to select a third surveyor who is a chartered surveyor with a sound knowledge of the Act and extensive experience of administering its provisions. The appointing owner should be advised of the name and address of the third surveyor.

## 5.2 Who may act as surveyor

---

Anyone who is a party to a dispute may not be appointed as a surveyor in that dispute. Apart from this, there are no statutory restrictions on who may be appointed as a surveyor under the Act.

Despite this, before accepting appointments surveyors should ensure that they are able to administer the statutory requirements fairly and independently, and should therefore consider whether there is a potential or perceived conflict of interest that could prevent this (see paragraph 5.5), for example a familial or employer/employee relationship.

This requirement to avoid a potential or perceived conflict of interest is especially applicable to third surveyors receiving referrals where there is some relationship between him or her and either of the owners or either of the appointed surveyors.

## 5.3 Status of a party-appointed surveyor

---

Any surveyor appointed under section 10 of the Act is undertaking a statutory role. The appointed surveyor should seek to conclude an award that fairly sets out the rights and obligations of both owners, ensuring that the work specified in the award is permissible under the Act. The award should enable the building owner to carry out the work without causing unnecessary inconvenience to adjoining owners or occupiers.

The appointed surveyor should seek to identify and represent the interests of the appointing owner, but this should not extend to following instructions from their appointing owner where these conflict with their duties under the Act.

The appointed surveyor cannot be discharged by an owner. The appointment only comes to an end if the surveyor dies, becomes or declares him or herself incapable of acting. This ensures that the surveyor is able to conclude an award without undue interference from the appointing owner.

It is necessary for the surveyor to act diligently in considering information provided and in seeking to reach agreement and conclude an award. The Act allows one surveyor to conclude an award alone if the other surveyor has refused to act effectively, or has neglected to do so for ten days after being so requested in writing.

## 5.4 Appointment as agreed surveyor

---

The two owners may expressly concur in the appointment of an 'agreed surveyor'. This surveyor must act impartially and work towards concluding an award that is fair to both owners, regardless of which owner made the initial appointment, or if one owner is an established client. The agreed surveyor must conclude an award that sets out the rights and duties of both parties and the works to be carried out.

If an agreed surveyor refuses to act, or neglects to act for a period of ten days after being required in writing to do so by either party, then the appointment will end. Both owners must appoint another agreed surveyor, or separate surveyors, who will then settle the dispute.

## 5.5 Professional conduct issues

---

The surveyor must appreciate that the role of appointed surveyor differs significantly from the role in providing advice on the application of the Act, or in serving notices on a client's behalf. Once appointed under the Act, the surveyor performs a statutory function and is therefore no longer solely responsible to the client, but owes duties to both parties to the dispute (see chapter 6). To emphasise this, it is customary for the surveyor to refer to the party who makes the appointment as the 'appointing owner' rather than the client.

A surveyor engaged on the supervision of works that trigger the requirement for service of notice may not be best placed to accept an appointment as the building owner's surveyor. The surveyor should therefore ensure that no conflict of interest

arises from these or other circumstances before accepting appointment. Particular difficulties may arise where a surveyor considers accepting an appointment as an agreed surveyor. In practice, there may be a perceived conflict of interest if a candidate for agreed surveyor had previously acted as the building owner's agent.

In these situations, the surveyor should not accept appointments without having first drawn the potential, or perceived, conflict of interest to the attention of both parties and then received their written confirmation that they have no objections. However, there may be circumstances in which professional judgment dictates that it would be prudent to decline to act.

Similarly, surveyors should not make nominations for, or agree to nominate, a selected third surveyor which may give rise to a potential or perceived conflict of interest, for example if the nominee is a consultant to the appointed surveyor or the appointed surveyor's firm.

## 5.6 RICS Regulation issues

---

It is an RICS Regulation requirement that all chartered surveyors (firms or individuals) have, and advise their clients of the existence of, a complaints handling policy (CHP). They should also be prepared to provide a copy of the policy when asked. It is, however, well established that a party involved in a party wall dispute cannot use the CHP to influence or intimidate a surveyor who is acting in a statutory role under the *Party Wall etc. Act 1996*. The CHP also cannot be used to avoid or delay satisfying award obligations under that statutory process.

RICS recognises the statutory independence of the surveyor in party wall matters and considers that the CHP does not apply to a surveyor during the statutory process. Both surveyors and owners should fully understand that nothing in the RICS Rules of Conduct or the RICS CHP can adjust or modify an award, as this can only be achieved via an appeal. RICS therefore will not deal with a complaint brought under the CHP against a party wall surveyor until after any appeal to the court has been fully considered and determined.

However, RICS members acting in this role are still obliged to comply with the RICS Rules of Conduct in their general duties.

Issues outside the statutory process may be dealt with by RICS Regulation and, if necessary, an RICS Conduct Panel. Examples of such issues are rudeness, or failure to respond to repeated correspondence from an owner or assisting a RICS officer investigating a matter subject to a complaint.

# 6 Powers and duties of appointed surveyor

---

## 6.1 Statutory purpose of surveyors' role

---

Once appointed, either the agreed surveyor acting alone, or the three surveyors (two party-appointed surveyors and the third surveyor) acting collectively constitute what has been referred to by the courts as a practical tribunal.

The practical tribunal's role differs from that of most conventional tribunals (for example, the courts and arbitrators). It is charged with the specific task of enabling the building owner to exercise his or her rights under the Act without causing unnecessary inconvenience to adjoining owners or occupiers. It achieves this by regulating the nature, time and manner of the construction operations even-handedly between the parties.

The actions of the members of a practical tribunal are restricted, as they must ensure that they act within their proper jurisdiction and that they only exercise powers granted to them by the Act. Where surveyors exceed either their jurisdiction or their statutory powers, their awards, or some part thereof, may be invalid and set aside by the courts, or may be unenforceable. The surveyors are also subject to legal duties, both individually and as members of the tribunal.

## 6.2 Surveyors' duties

---

The first statutory duty of the appointed surveyors is to select a third surveyor to complete the tribunal. Before agreeing that selection, each surveyor should be satisfied that the nominee has substantial experience of the statutory proceedings and adequate expertise to fairly determine a statutory dispute if one is referred to him or her. Surveyors should not select third surveyors where this may give rise to a potential or perceived conflict of interest. The tribunal is then under a duty to act impartially between the parties. It also owes a duty to perform its obligations diligently and to exercise reasonable care.

When acting as party-appointed surveyors they owe a duty of care to their own appointing owner,

but will still continue to owe a duty to both parties to perform the obligations diligently and impartially. Hence, whilst safeguarding the interests of their own appointing owner within the tribunal, surveyors should not follow an owner's instructions where they would frustrate the proper function of the legislation.

## 6.3 Surveyors' jurisdiction

---

The surveyors will only have jurisdiction if the tribunal of which they form a part has been properly constituted. The following paragraphs relate to the Act's requirements for the proper constitution and competence of the tribunal, as well as the authority it gives to the surveyors.

### 6.3.1 *Proper constitution of the surveyor's tribunal*

The Act sets out detailed requirements for the composition of the surveyors' tribunal and the appointment of the surveyors in section 10(1)–(9). Where there has been a failure to follow the requirements precisely, the surveyors may lack jurisdiction and the courts may declare their awards to be invalid. Because the Act sanctions the interference with the property rights of adjoining owners, the courts require the Act's requirements to be followed scrupulously and have advised that the approach of surveyors to those requirements ought not to be casual.

### 6.3.2 *Competence of the surveyors' tribunal*

Section 10(10) of the Act provides that the surveyors may only make awards on matters that are in dispute between the parties and are connected with work to which the Act relates. The nature of 'disputes' within the meaning of the Act has been explored in paragraph 4.4, and there will rarely be any doubt as to whether matters are in dispute. The necessary degree of connection between the dispute and work to which the Act relates often causes more difficulty.

Although appointed surveyors are frequently called upon to resolve a variety of disputes between the parties, they must be careful to distinguish

between those that must be settled by consensual negotiation and those that can be properly addressed by their award. Disputes about crane oversailing, easements and the general conduct of piling operations outside the prescribed distances are all examples that would have to be settled by consensual negotiation. As such, appointed surveyors have no statutory jurisdiction to address them in an award.

### 6.3.3 Authority of the surveyors

Where surveyors have jurisdiction under the Act, they have power under section 10(12) to make binding awards. These may determine any of the following issues:

- the right to execute work under the Act;
- the time and manner of executing any such work; or
- any other matter incidental to the dispute referred to them, including the costs of making the award.

An award which purports to determine some other issue will have exceeded the statutory powers (*ultra vires*), thus the award or part thereof may be invalid.

The surveyors' power to determine the right to execute work is, in reality, only a declaration of the existence of a particular statutory right in a particular situation. The surveyors have no power to confer new rights on the parties. On the other hand, the power to determine the time and manner of execution of work is central to the surveyors' role.

Surveyors have an express power, under this heading, to adjudicate on the professional costs of making the award. They also have the power to implement the statutory rules on compensation, making good and the liability for the expenses of the work. Surveyors should, however, be extremely cautious about assuming the existence of powers to deal with matters that are in some way incidental to the dispute referred to them.

The Court of Appeal has confirmed that surveyors do not have any authority to award legal costs for the time and expense of threatening to seek an injunction, or similar relief, via the courts for non-compliance with the Act. This does not mean a wrongful party is absolved of the responsibility for such fees and costs, only that the administration of the recovery via a party wall award would be found to be incorrect.

## 6.4 Enforcement of surveyors' awards

---

A valid award creates legal obligations between the parties. Therefore, a breach of the terms of the award creates a legal liability, which can form the basis for court action by an aggrieved party. A successful action in the courts would result in a court judgment, which could then be enforced against the defaulting party in the normal way.

The award is for the benefit of the owners, so in the event of non-compliance with an award, it is for the owners to take enforcement proceedings. Surveyors should therefore always recommend that clients obtain legal advice in respect of enforcement of any part of an award.



# 7 Surveyors' role in preparing primary award

---

## 7.1 Preparing schedules of condition

---

While not a statutory requirement, a surveyor is recommended to record a schedule of condition of the relevant parts of the adjoining owner's building and append it to an award. A schedule should be compiled before any building works start and should include those parts of the adjoining building and grounds that may be affected by the works.

The extent of the schedule depends on the nature and location of the proposed works. For example, where it is proposed to build higher than the adjacent building, the latter's roofs should be closely examined as they could be damaged by falling debris or materials. It is particularly important to record cracks, their location and, where relevant, their width. It is often useful to include a simple drawing, as photographs do not always show minor defects.

Ultimately, the purpose of the schedule is to identify to what extent any claim for damage is valid and, if it is, the extent of the damage. The schedule should be sufficient to avoid leaving significant areas of doubt, which will be a matter for the judgment of the two surveyors.

It is usual for the building owner's surveyor to prepare any schedule of condition, which has to then be checked and agreed by the adjoining owner's surveyor. A sample form of a schedule of condition is shown in Appendix C.

## 7.2 Agreeing the contents of the award

---

The building owner's surveyor will usually prepare a draft award and send it to the adjoining owner's surveyor for comments. While there is no prescribed award format, a sample is shown at Appendix D. An award will usually include relevant drawings of the notifiable works, method statements and any limitations on the time and manner of carrying out the work with any schedule of condition appended.

The surveyors agree the working conditions applicable only to the works to which the Act relates, such as the hours for noisy works, whether

weekend working is acceptable, protection required to any exposed party walls, security arrangements, and costs to be paid and by whom. Method statements may be attached for particular operations, such as demolition or details of access to the adjoining owner's premises.

It is for the surveyors to agree the terms of the award. While the surveyors should consult with their owners in respect of ascertaining specific preferences and/or requirements, they should not present the draft award to their appointing owners for approval as this could give rise to a conflict with the requirement for impartiality.

## 7.3 Provision for disturbance, making good and compensation

---

The award should have appropriate provision for the making good of damage caused by relevant works under section 2(2) of the Act and, where appropriate, for the payment of compensation for damage caused by the stated works under section 1. The surveyor should make reference to the Act to determine the precise situations in which such compensation and making good are applicable. More generally, section 7(2) also requires the building owner to pay compensation for loss or damage caused by any works executed in pursuance of the Act. For example, if car parking is impeded because of scaffolding, it may be justifiable to require the building owner to pay the cost of providing parking elsewhere.

Where such loss or damage can be anticipated in advance of the work, provision should be made for payment within the award. Note that such compensation is only available for justifiable and calculable losses, and not for mere inconvenience. (See also paragraph 8.4.)

Where a building is laid open under section 2(2)(e), the surveyor should also consider whether it is appropriate for the adjoining owners or occupiers to receive a payment in respect of inconvenience and disturbance under section 11(6). If so, a fair allowance should be assessed for this in advance of the work and included in the award provisions.

## 7.4 Expenses of the works

---

Section 11 of the Act sets out guidelines on the responsibility of the owners for the expenses of works. In most cases the expenses of works under the Act shall be defrayed by the building owner, because the building owner, who has organised the works, will benefit from them while the adjoining owner usually will not. However, there are exceptions to this rule which include the following.

Where building works are required because party structures or party fence walls (for which there is a joint liability) are defective, the costs of remedial works, and the proportion of fees that relate to them, should be split appropriately between the owners. The sum that each should be required to pay will have regard to the use each makes of the structure, the benefit that each derives from the structure and the responsibility for the defect.

Another exception is when improvements or extensions to the building owner's property are carried out at personal cost and the adjoining owner subsequently makes use of those works. In such case, the adjoining owner may have a liability to make a payment to the building owner (or the successor in title). This is calculated as a fair proportion of the costs and expense of the relevant portion of the original works at present-day costs.

Where the building owner carries out works to improve his or her property and lays open the adjoining owner's premises, 'a fair allowance' is to be paid for disturbance and inconvenience suffered by the adjoining owner. If damage is caused to the adjoining owner's property, the adjoining owner has the right to a financial sum covering the costs for remedial works, as opposed to having the remedial works executed.

Where a building owner proposes to reduce the height of a party wall or party fence wall (to no less than 2m), the adjoining owner can serve a counter-notice within one month of the original notice requesting the existing height of the wall to be maintained. If so, the adjoining owner has to pay a due proportion of the cost of retaining that wall, including the full cost of its subsequent maintenance exceeding what is necessary for the purposes of the building owner.

## 7.5 Costs of the award (including surveyor fees)

---

Reasonable costs are generally considered those incurred in obtaining and making an award, which includes the reasonable fees of the appointed or selected surveyors and other appropriate advisers. Responsibility for these costs is determined by the surveyors making the award, but only to the extent that they have been properly incurred in administering the Act's provisions.

A failure of the appointed surveyors to agree upon the reasonable quantum of a claimed cost should not prevent them from making and serving an otherwise agreed award, with the issue of the reasonable quantum being subsequently referred to the third surveyor. The award should determine responsibility for the cost and quantify an interim sum on account at a level agreed between the surveyors, with the balance of the amount claimed referred to the third surveyor for determination. However, given that only the surveyor(s) making an award can determine responsibility for costs, if the appointed surveyors cannot agree upon which owner is responsible for a specific cost, then that matter must be resolved before the award is made (by referral to the third surveyor for direction, or to determine the responsibility by making an award).

### 7.5.1 Surveyor fees

Responsibility for costs usually follows the apportionment of expenses of the works and is therefore generally determined to rest with the building owner. Where the expenses of the works are defrayed by both owners, the costs of making the award may be apportioned accordingly, or it may be determined that the owners are responsible for paying their own appointed surveyor's fees.

It is usual for the award to include the adjoining owner's costs by way of surveyor fees as a lump sum based on time incurred, including an allowance for any necessary subsequent inspections. In addition, an agreed hourly rate is generally quoted if further involvement becomes necessary to determine subsequent disputes arising from change of design, problems found on-site or damage. Only fees that are proportionate to tasks necessary to making the award should be included in the award. The surveyor appointed by the building owner would normally agree fees directly with the latter, but there is no reason why

the responsibility for, and reasonableness of, these cannot be determined in an award.

Despite the custom and practice of the surveyors addressing invoices to the owner determined responsible for the costs, the courts have ruled that there is no contractual or statutory basis for this arrangement and only an owner can enforce an award in respect of his or her awarded costs. Surveyors should therefore take care in the wording of awards in respect of costs and in the contractual arrangements made with their appointing owners in respect of their fees.

### 7.5.2 *Advising engineer fees*

It may be necessary for one or both of the appointed surveyors to seek advice from an independent engineer to consider the suitability of technical proposals of an engineering nature, which would be outside of their expertise (for example, the adequacy of temporary shoring). It may be that in order to ensure the stability of its property is being adequately protected, the adjoining owner undertakes to pay the independent engineer to advise on this matter. In such circumstances, responsibility for this cost by way of engineer fee should be dealt with in exactly the same way as surveyor fees in paragraph 7.5.1.

Alternatively, the independent engineer's fee may be a contractual responsibility of the surveyor(s) instructing the engineer and is to be paid as a disbursement of the appointed surveyor. In such case, it would be prudent for this 'disbursement cost' to be put in a separate clause from the surveyor fee so that the engineering advice element of the cost is distinctly identified. As with any cost, surveyors can only determine responsibility for reasonable costs that are proportionate to the necessary tasks to facilitate the making of the award. Therefore, in this context only engineer's fees that constitute a reasonable cost should be included in an award.

### 7.5.3 *Other consultant fees*

It may be appropriate in specific circumstance for the appointed surveyors to seek advice from a specialist in another discipline, for example a valuer or a quantity surveyor. As with engineer fees, a determination of responsibility for such costs by way of consultant fees considered reasonable should be distinctly identified in a separate clause of the award.

Solicitor fees may constitute valid costs for which the surveyors may determine responsibility, but they must be incurred directly in facilitating the making of an award. For example, they may be for advice on the interpretation of the Act or the applicability in the specific circumstances of a given situation.

It should, however, be especially noted that solicitor fees incurred in advising on litigation matters do not constitute a valid cost for the appointed surveyors to consider or determine responsibility for within an award. Examples of such excluded matters are: demanding notice be served, threatening injunctive proceedings or successfully obtaining an injunction until full compliance with the Act has been achieved. Costs for such matters should be resolved as part of the litigation proceedings or any settlement agreement.

## 7.6 **Signature and service of awards**

---

Once an award has been agreed it should be signed and dated by the agreed surveyor, by two of the three surveyors or by the third surveyor, as appropriate.

Where appointed surveyors make an award it must be served in compliance with section 10(14) of the Act, which states that 'where the surveyors appointed by the parties make an award the surveyors shall serve it forthwith on the parties'. Where an award is made by the selected third surveyor it should, after payment of the costs of the award, be served forthwith on the parties or their appointed surveyors, who must then forthwith serve the award on their appointing owner. The award must be served on each of the owners, or an authorised agent, otherwise service of the award cannot be deemed to be effected.

The owners should be advised of their right to appeal to the county court against the award within 14 days of its service.

## 7.7 **Entry onto adjoining land**

---

Section 8 of the Act gives the building owner, and the latter's servants, agents and workmen the right to enter the premises of the adjoining owner for the purpose of executing any work in pursuance of the Act. However, access is only available during usual working hours.

If it is known that access to an adjoining owner's property will be required to facilitate the notified works, then it is prudent to include this requirement in the initial notice. This may require a notice for access to be served on an occupier who is not an owner as defined by the Act and is not a party to any award. Notice of any access requirement must be served upon any adjoining owner and occupier at least 14 days in advance, although in case of emergency such notice may be served as is reasonable in the circumstances.

Details of access should be determined by the appointed surveyors when agreeing an award, and should include such restrictions and safeguards as are necessary to protect the adjoining owner. It is generally accepted that there is a right to erect scaffolding to facilitate the access, if reasonably necessary to facilitate works in pursuance of the Act. Such scaffold can remain in place 24 hours a day so long as it is required to facilitate those works.

Preventing a statutory right of entry is a criminal offence. If access is not available, then the building owner may break in if accompanied by a police officer. Appointed surveyors may have access to the land of the building owner or adjoining owner to carry out their role, subject to notice.

## 7.8 Security for expenses

---

The Act makes provision for both the building owner and adjoining owner to request security for expenses. Security might relate, for example, to the cost of remedying works left uncompleted, compensation payable under the Act or disturbance allowance.

It will usually only be appropriate to make provision for security where there is a particular risk, such as a risk of non-completion or of default in carrying out the works, or a real risk that the works will cause damage to the adjoining owner. The financial circumstances of the building owner may be relevant. The risk of default and foreseeable damage should be assessed in each case where the request for security is not agreed by the building owner.

Requests for security of expenses are not appropriate for a general risk of damage caused by failure to follow the terms of an award or accidental damage. It is for the owner, not the surveyor, to

request security. The surveyor is not statutorily obliged to advise the appointing owner on security of expenses issues, unless there is a dispute in respect of requested security. If the adjoining owner wishes to serve notice requiring the building owner to provide security, this must be done before work commences. If the parties cannot agree the amount or nature of the security, then this will be determined by the surveyors. The arrangements for payment of security should, in any event, be described in the award.

Where an adjoining owner has required the building owner to carry out additional works, for example under section 4 of the Act, the building owner can request security from the adjoining owner. If this is not paid within one month of the request or award determining a dispute in respect of requested security, the building owner is not obliged to comply with the counter-notice. As with security required by an adjoining owner, all arrangements should be described in the award.

Security for expenses can be held in a number of ways. This can be in an Escrow bank account with stipulation that the funds are only to be released on the signature of two of the three appointed surveyors (or the agreed surveyor). Alternatively, the funds can be held in a client account of a firm of chartered surveyors or solicitors, subject to appropriate safeguards and undertaking regarding the holding and especially the release of the funds.

It is the view of RICS Regulation that all security of expenses money held by an RICS member or an employee of an RICS regulated firm, under section 12(1) of the Act shall, for the purposes of the RICS Rules of Conduct, be considered to fall under the full protection of the RICS regulatory scheme for client accounts.

Security of expense is not intended to be a punishment or control method over owners. Therefore on large projects as the areas of risk are removed, the phased return and release of the money held as security should be tightly administered. It will be common on small or medium scale projects for money held as security to form part of the capital cash flow. The administration of money should therefore be viewed as a serious financial responsibility of the surveyors, who should be proactively working together to achieve the timely and correct administration of the process.

The calculation for the sum needed to provide security of expenses under the Act should be realistic and based on a balanced view of the potential future needs. For example, if the risk following the demolition of a building is the long term exposure of the party wall to the elements, then the extent of security of expenses is based on the area of party wall that would need to be returned to a weather tight condition and those foreseeable costs that would need to be incurred to achieve the works.



# 8 Surveyors' role subsequent to publication of primary award

---

## 8.1 Interim and final inspections

---

It is the building owner's responsibility to comply with the terms of the award.

Within the award, the appointed surveyors may include a provision for reasonable inspections to be carried out by them or their advisers. They may be required to ensure that specific conditions of the award are being complied with, or to inspect any detail or structure opened up during the works.

Appointed surveyors commonly provide for appropriate interim or final inspections in the primary award where the surveyors determine them to be necessary.

## 8.2 Design changes

---

Where there are changes to the design of works included in the award, they must either be agreed by the parties as anticipated by section 7(5) of the Act or, in the event of disagreement between them, be referred to the surveyors to be determined by a further award, termed an 'addendum award'.

Surveyors can obtain their appointing owners' authority to agree such changes on their behalf. In these circumstances where the surveyors are able to reach agreement, it is then recorded in an exchange of letters between them. In such case, there is no requirement for an addendum award, even for extensive changes in design.

## 8.3 Where additional work becomes necessary

---

Subsequent to the service of a notice, the building owner may wish to undertake additional work under the Act that was not referred to in the original notice.

Where this work is closely related to that described in the original notice, it may legitimately be considered as a design change and dealt with according to the procedures described in

paragraph 8.2. In cases of doubt, surveyors should consult with their appointing owners to confirm that they are in agreement with matters being handled in this way.

Where the additional work is entirely different or unrelated to that proposed by the original notice, the building owner will only be permitted to undertake it in accordance with the Act's requirements. In the absence of consent by an adjoining owner, there may be no alternative to serving a new notice and starting the statutory procedure afresh.

Surveyors should attempt to resolve the issue consensually. They may achieve this by reaching agreement to the additional works on the owners' behalf, assuming that they have their appointing owners' authority to do so, without the requirement for service of a further notice. Such agreement should always be made in writing and copied to the owners. This reflects the inherent right of parties to agree to works under the Act without service of notice, which is expressly stated (in the case of section 2 works) in section 3(3)(a).

Provided surveyors obtain all adequate additional authorities, they can expedite the procedure by receiving the notice, consenting to the works and waiving the statutory notice period for commencement of the works on their appointing owner's behalf.

## 8.4 Awarding compensation and making good

---

Surveyors should require the building owner to 'make good' damage caused by the works where appropriate under the Act. Express provision will usually have been made for this in the primary award (see paragraph 7.3).

The adjoining owner can instead require the surveyors to determine the cost of the making good, and this sum must then be paid to the adjoining owner in lieu of making good. Where damage is caused by works under section 1, the



Act provides for the payment of compensation rather than making good. Surveyors should, therefore, require the building owner to pay compensation for such damage unless both parties have expressly consented to the building owner making good.

In addition to addressing damage to the adjoining owner's property in this way, surveyors may also require the building owner to pay compensation for certain non-physical losses or damage caused by the works. Surveyors should refer to section 7(2) in this respect. For compensation to be payable in these circumstances, the adjoining owner must have experienced an actual loss or damage rather than simply an inconvenience.

## 8.5 Changes of ownership

---

The Act makes no express provisions for changes in ownership, and there is no clear authority setting out the consequences of a change in ownership. Current custom and practice is identified in the following paragraphs.

If the adjoining owner changes, the appointment of the adjoining owner's surveyor continues and

the rights and duties of the adjoining owner pass to the successor in title. This avoids unnecessary delay, cost and inconvenience to the building owner by virtue of a change of adjoining owner. It also prevents an adjoining owner from thwarting a building owner's intention to proceed with work, for example, by transferring ownership of the adjoining property to a subsidiary company.

Where the building owner changes, the procedure must start afresh as the building owner who intends to carry out the work must be the one who served notice. In addition, the adjoining owner's response to the initial notice is likely to have been influenced partly by the identity and intent of the building owner at the time.

To avoid delay to the statutory proceedings, surveyors can facilitate a change of building owner, with the consent of the adjoining owner, by service of new notice, waiving the notice period and continuing the negotiations with only the building owner's name being changed. The same situation would apply when an award has been completed and work is taking place – with the already appointed surveyors reproducing the same award except for naming the new building owner.

# 9 Role of the third surveyor

---

## 9.1 Nature of the role

---

A party-appointed surveyor who considers that the other appointed surveyor is taking an unreasonable attitude has the option of requesting the third surveyor's involvement to settle the point in dispute. The Act also allows the appointing owners the same right, although in practice it is fairly rare for an owner to take the initiative.

The third surveyor's decision will then be embodied in an award that will deal only with the referred dispute. The party-appointed surveyors will retain jurisdiction over all other matters in the original notice.

The appointed surveyor must declare at the outset upon contacting another surveyor for guidance that the latter is the selected third surveyor in the matter. However, any verbal advice or guidance so given does not constitute a determination.

## 9.2 Preliminary notification

---

Where party-appointed surveyors propose to refer a dispute to the third surveyor, they should inform their appointing owners of the points at issue, the efforts they have made to reach agreement and the impact in terms of time and cost of referring the dispute to the third surveyor. The owners may, for example, be prepared to concede the point in dispute rather than risk further delay and expense, or make the referral themselves.

Before a party-appointed surveyor refers a dispute to the third surveyor, he or she is advised to confirm this intention in writing to the other appointed surveyor. Although the Act does not require this, it is suggested that failure to do so could be taken into account in awarding costs.

## 9.3 Referral to the third surveyor

---

The Act does not lay down the form of referral to the third surveyor, but it is suggested that, except in the most urgent cases, submissions should be in writing. The appointed surveyors should clearly define the disputes on which the third

surveyor's decision is sought and attach all relevant documents.

The case should be presented in such a way as to enable the third surveyor to form a clear idea of the points needing decisions, and the main areas of factual or technical dispute. This will avoid uncertainty as to the scope of the third surveyor's jurisdiction and will ensure that costs and time required by the referral are minimised.

It should also be made clear that the submissions are a formal request to the third surveyor to deal with the matter, not simply a request for guidance.

## 9.4 Procedure on referral to the third surveyor

---

Once a dispute is referred to the third surveyor, the Act simply requires that the third surveyor shall make the necessary award. The Act is silent as to both the procedure to be followed, and who is to control or decide the procedure. However, the words of the Act suggest that the procedure is to be laid down by the third surveyor, who has responsibility to determine the disputed matters.

The Act does not specifically require the third surveyor to observe the rules of natural justice. However, the following should still be observed:

- The third surveyor should give each party a fair opportunity to present its case and challenge the other party's case.
- The third surveyor should avoid, if possible, receiving information or submissions from one party in the absence of the other. Where this does occur, a note should be made and sent to both parties.

Subject to this, the third surveyor is free to adopt whatever procedure appears appropriate. Where the dispute has been referred by way of written submissions from one surveyor or owner, the third surveyor ought to call on the other surveyor or owner to reply to those submissions within a certain time. The third surveyor may wish to visit the site, meet the parties' surveyors and consider reports, drawings, photographs and other relevant material before reaching a decision.

## 9.5 Third surveyor's award

---

The third surveyor can only deal with the referred matters in dispute and does not, therefore, have power to carry out a general review of the previous actions of the party-appointed surveyors, and still less to reopen any awards they have made.

The third surveyor is not required to give reasons for his or her award, which is more in the nature of an expert determination (similar to any award made by surveyors under the Act). However, it is recommended that the third surveyor should do so in order to enable the owners to understand the basis of the decision and, if appropriate, to consider whether to appeal the award. Subsequent to service of a third surveyor's award, there is no obligation on the third surveyor to respond to queries made by either party or surveyor.

The award should deal with the costs incurred, pursuant to section 10(13), which are within the discretion of the third surveyor. Responsibility for costs will usually depend on the determination, but may have regard for the conduct of the parties or the surveyors.

Section 10(15) of the Act deals with service of a third surveyor's award. The third surveyor is to serve it forthwith on the parties, or their appointed surveyors, after payment of the costs of the award. The third surveyor is entitled to retain the award until those costs are paid.

In practice, the third surveyor may prefer to serve the award on the party-appointed surveyors, and (though this is not mandatory) include in the award a provision that they shall forthwith serve the award on the parties.

# 10 Challenging the award and appeals to the county court

---

## 10.1 Challenging the award

---

Section 10(16) of the Act provides that ‘the award shall be conclusive and shall not except as provided by this section be questioned in any court’. This could be interpreted as precluding any challenge to the award except by way of appeal to the county court. However, it has been held that it is open to a party to contend that an award is *ultra vires* and hence not a valid award, notwithstanding the absence of an appeal to the court.

The distinction lies between a valid award, which can only be challenged by appeal, and an award

which is invalid due to a failure to comply with the Act, which can be treated as invalid in subsequent proceedings. The invalidity of the award can also be raised on an appeal.

## 10.2 Appeals to the county court

---

Section 10(17) of the Act confers a right of appeal by either party (i.e. building owner or adjoining owner) against an award. The appeal is to the county court and must be made within 14 days beginning with the day on which an award made under section 10 is served on that party.

# Appendix A: Draft letters





# 1 Surveyor's statutory appointment and authority

---

## **Party Wall etc. Act 1996**

I/We <insert name(s) of the appointing owner(s)>

of <insert appointing owner's main postal address>

confirm we are an owner as defined by section 20 of the above Act of:

<insert address of the property to be worked on or adjacent property as applicable>

and hereby AUTHORISE:

<insert surveyor's name>

<insert surveyor's practice and address>

to sign, issue, serve, receive and respond to all notices and requests under the Act relating to the works currently proposed <insert 'at' or 'adjacent to'> the above property.

In the event of a dispute or deemed dispute arising, or having arisen, within the meaning of the Act we hereby appoint the said <insert surveyor's name> as our surveyor in accordance with section 10(1) <insert 'a' or 'b' or 'a or b'> of the Act.

We further authorise <insert surveyor's name> to make all requests and appointments under the Act on our behalf which may be necessary to expedite the progress of the matter.

Signed: ..... Date: .....

Print name: .....

**Note:** Duplicate signature, date and name lines as necessary for joint multiple owners.

## 2 To accompany a typical section 3 or 6 notice

---

<insert name(s) of the adjoining owner(s)>

---

<insert adjoining owner's main postal address>

---

Under the *Party Wall etc. Act 1996* <insert name(s) of the building owner(s)> (the building owner) is obliged to serve you with the accompanying notice of the intention to carry out works which has the potential to affect your premises.

This letter is to explain in less formal terms that if you disagree with any of the proposed works you should concur in the appointment of an agreed surveyor, or appoint your own surveyor to safeguard your interests.

The surveyor's fee, under all normal circumstances, will be paid by the building owner, who will also be responsible for making good any damage that the works proposed may cause.

I would be grateful to learn whether or not you agree to the works proposed or, if you are intending to appoint your own surveyor, who this will be. Please complete and return the enclosed acknowledgment form giving this information and kindly tell me of any other person having an interest in the property, either as landlord or tenant.

I would be pleased to explain in further detail the formalities involved in these matters if you so wish.

Signed: ..... Date: .....

Print name: .....

Authorised to serve notices for <insert name(s) of the building owner(s)>

---

**Note:** Notices will normally be sent to a lay adjoining owner and, while not required, this accompanying letter will assist in giving meaning to the legal requirements.

### 3 Requiring an adjoining owner (or building owner\*) to appoint a surveyor

---

<insert name(s) of the adjoining/building owner(s)>

of <insert adjoining/building owner's main postal address>

#### **Party Wall etc. Act 1996**

On <insert date of notice> notice was served upon you concerning proposed works <insert 'at' or 'adjacent to'> your property. As you were advised at that time, the above Act required you to appoint a surveyor if you dissent from the proposals. You have not signified your assent within 14 days and therefore you are deemed to have dissented and must now appoint a surveyor.

On behalf of the <insert 'building' or 'adjoining'> owner, I formally call upon you to appoint a surveyor in accordance with section 10 of the above Act, by concurring in my appointment as an agreed surveyor or appointing your own surveyor. If within ten days you fail to do so and notify me or the <insert 'building' or 'adjoining'> owner, the <insert 'building' or 'adjoining'> owner will make an appointment on your behalf.

Yours

Signed: ..... Date: .....

Print name: .....

**Note:** *If signed by the surveyor, insert 'authorised to sign on behalf of' and the name(s) of the owner.*

*Under section 10(4) the adjoining owner is obliged to appoint his or her surveyor within ten days of a written request where a difference has arisen. This letter provides such formal request.*

\* with suitable amendment if no notice has been served

## 4 Requiring an appointed surveyor to act effectively

---

<insert name of the surveyor>

---

<insert surveyor's postal address>

---

### **Party Wall etc. Act 1996**

On <insert date> I sent you <identify what was requested>  
for your consideration but have received no effective response.

In accordance with section 10(7) of the above Act, I now formally call upon you to  
<identify specifically what it is that is required of the other surveyor> and give you notice that if you fail to do so within ten days, I will exercise my authority to proceed *ex parte*.

Yours

Signed: ..... Date: .....

Print name: .....

**Note:** This gives ten days written notice, in accordance with section 10(7), to an appointed surveyor to act effectively. Failure to do so will enable the other surveyor to proceed *ex parte*.

# 5 To appointing owners upon service of the party wall award

---

<insert name(s) of the owner(s)>

---

<insert owner's main postal address>

---

## **Party Wall etc. Act 1996**

I enclose the party wall award made and signed by the two appointed surveyors which sets out the rights and duties in connection with the proposed work.

I must point out that under section 10(17) of the Act you are entitled to appeal against the award in the county court within 14 days if you feel that it has been made improperly. To the best of my knowledge, however, there is nothing in the award which should cause you to take this action.

Yours

Signed: ..... Date: .....

Print name: .....

*Enc. party wall award*

**Note:** You must send the award and should inform the appointing owner that he or she has the right of appeal. The Act obliges the surveyors to serve the award on their appointing owners promptly and this letter, when accompanying the award, sets out the legal position without encouraging the owners to appeal.

## 6 Draft solicitor's or chartered surveyor's undertaking for holding security monies

---

<insert solicitor's/surveyor's reference>

Dear Sirs

**RE: OUR CLIENT** <insert name(s) of the building owner(s)>, **THE BUILDING OWNER,**  
**AND THE PROPOSED WORKS AT** <insert address of the building owner's property to be worked on>

### ***Party Wall etc. Act 1996***

We confirm that our above-named client has deposited £ <insert amount of security monies held> as requested security of expenses in respect of *Party Wall etc. Act* matters relating to the above proposed development.

We undertake that these monies will be held by us in our client account and, unless required by an order of the court, will be released only as and when directed by the instruction of any two of the three surveyors, or by the third surveyor.

The surveyors authorised to direct the release of the security monies are:

<insert name and practice of building owner appointed surveyor>, the building owner appointed surveyor, <insert name and practice of adjoining owner appointed surveyor>, the adjoining owner appointed surveyor, and <insert name and practice of selected third surveyor>, the third surveyor, or the properly appointed or selected successors.

Yours sincerely

Signed: ..... Date: .....

Print name: .....



## **Appendix B: Draft notices**



# 1 Line of junction notice: *Party Wall etc. Act 1996*, section 1

---

To:           <insert name(s) of the adjoining owner(s) or 'the Owner'>           (Adjoining owner)

of           <insert adjoining owner's main postal address>          

I/We           <insert name(s) of the building owner(s)>           (Building owner)

of           <insert building owner's main postal address>          

being owner(s) of the land known as  
          <insert address of the building owner's property to be worked on>          

which adjoins your land known as  
          <insert address of property adjacent to the works>          

HEREBY SERVE YOU WITH NOTICE THAT *<insert the relevant statement(s) marked \* as may be applicable>*

- \* under section 1(2), subject to your written consent it is intended to build on the line of junction of the said lands a party wall/party fence wall.
- \* under section 1(5), it is intended to build on the line of junction of the said lands a wall wholly on my/our own land.
- \* under section 1(6) it is intended to place projecting footings and foundation below the level of your land at my/our expense.
- \* under section 7(4) it           <insert 'is' or 'is not'>           proposed to employ special foundations placed on your land, which would require your written consent.

The proposed works as shown on the accompanying drawings are:  
          <give relevant details of the proposed works and describe the proposed wall>            
\_\_\_\_\_

It is intended to commence works           <insert 'after one month' or 'on [date]>           or earlier by agreement.

In the event of matters arising for settlement I/we would appoint           <insert surveyor's name>            
of           <insert surveyor's practice and address>            
as my/our surveyor           <and if appropriate add 'or as an agreed surveyor'>           .

Signed: ..... Date: .....

Print name: .....

**Note:** *If signed by the surveyor, insert 'authorised to sign on behalf of' and the name(s) of the building owner(s). Duplicate signature, date and name lines as necessary for joint owners signatures.*

## 2 Acknowledgment of line of junction notice

---

### **Party Wall etc. Act 1996, section 1(2)**

To be completed and returned to the building owner or the surveyor named on the notice

I/We <insert name(s) of the adjoining owner(s)>

of <insert adjoining owner's main postal address>

having received notice served by

<insert name(s) of the building owner(s)>

of <insert building owner's main postal address>

in respect of proposed works at

<insert address of the building owner's property to be worked on>

which adjoins my/our premises known as

<insert address of property adjacent to the works>

and in relation to the works proposed under section 1(2) (please delete two of the below options marked \* as appropriate)

\* hereby consent to the above works **OR**

\* hereby dissent from the above works and, a dispute having arisen, concur in the appointment of <insert surveyor's name> as an agreed surveyor **OR**

\* hereby dissent from the above works and, a dispute having arisen, appoint <insert surveyor's name>

of <insert surveyor's practice and address>

as my/our surveyor.

Signed: ..... Date: .....

Print name: .....

**Note:** Duplicate signature, date and name lines as necessary for joint multiple owners.

### 3 Party structure notice

---

To: \_\_\_\_\_ (Adjoining owner)

of \_\_\_\_\_

I/We \_\_\_\_\_ (Building owner)

of \_\_\_\_\_

being owner(s) of the land known as  
\_\_\_\_\_

which adjoins your land known as  
\_\_\_\_\_

HEREBY SERVE YOU WITH NOTICE THAT

Under section 2(2), and with reference to the \_\_\_\_\_  
separating the above premises, it is intended to carry out the works detailed below after the  
expiration of two months from service of this notice.

The proposed works are:  
\_\_\_\_\_  
\_\_\_\_\_

It is intended to commence works \_\_\_\_\_ or earlier by agreement.

Under section 5, if you do not consent to the works within 14 days you are deemed to  
have dissented and a dispute is deemed to have arisen. In such case section 10 of the Act  
requires that both parties should concur in the appointment of a surveyor or should each  
appoint one surveyor.

In those circumstances I/we would appoint  
\_\_\_\_\_

of \_\_\_\_\_  
as my/our surveyor \_\_\_\_\_ .

Signed: ..... Date: .....

Print name: .....

**Note:** If signed by the surveyor, insert 'authorised to sign on behalf of' and the name(s) of the building owner. Duplicate signature, date and name lines as necessary for joint owners signatures.

## 4 Acknowledgment of party structure notice

---

### **Party Wall etc. Act 1996, section 3**

To be completed and returned to the building owner or the surveyor named on the notice

I/We <insert name(s) of the adjoining owner(s)>

of <insert adjoining owner's main postal address>

having received notice served by

<insert name(s) of the building owner(s)>

of <insert building owner's main postal address>

in respect of proposed works at

<insert address of the building owner's property to be worked on>

which adjoins my/our premises known as

<insert address of property adjacent to the works>

and in relation to the works proposed under section 2(2) (please delete two of the below options marked \* as appropriate),

\* hereby consent to the above works **OR**

\* hereby dissent from the above works and, a dispute having arisen, concur in the appointment of <insert surveyor's name> as an agreed surveyor **OR**

\* hereby dissent from the above works and, a dispute having arisen, appoint <insert surveyor's name>

of <insert surveyor's practice and address>

as my/our surveyor.

Signed: ..... Date: .....

Print name: .....

**Note:** Duplicate signature, date and name lines as necessary for joint multiple owners.



# 5 Notice of adjacent excavation

---

## **Party Wall etc. Act 1996, section 6**

To:           <insert name(s) of the adjoining owner(s) or 'the Owner'> (Adjoining owner)

of           <insert adjoining owner's main postal address>

I/We           <insert name(s) of the building owner(s)> (Building owner)

of           <insert building owner's main postal address>

being owner(s) of the land known as  
          <insert address of the building owner's property to be worked on>

which adjoins your land known as  
          <insert address of property adjacent to the works>

HEREBY SERVE YOU WITH NOTICE THAT *<insert the word 'and' or delete the inapplicable option>*

Under section 6(1) it is intended to build within 3m of your building and to a lower level than the bottom of your foundations, by carrying out the works detailed below.

Under section 6(2) it is intended to build within 6m of your building and to a depth as defined in the Act, by carrying out the works detailed below.

IT *<insert 'IS' or 'IS NOT'>* PROPOSED TO UNDERPIN OR OTHERWISE STRENGTHEN OR SAFEGAURD THE FOUNDATIONS OF YOUR BUILDING/STRUCTURE.

The accompanying plans and sections numbered *<insert drawing numbers>* show the site of the proposed building and the excavation depth proposed.

The intended works are:           <insert a full description of the works>

It is intended to commence works *<insert 'after one month' or 'on [date]'* or earlier by agreement.

Under section 6(7), if you do not consent to the works within 14 days you are deemed to have dissented and a dispute is deemed to have arisen. In such case section 10 of the Act requires that both parties should concur in the appointment of a surveyor or should each appoint one surveyor. In those circumstances I/we would appoint           <insert surveyor's name> of           <insert surveyor's practice and address> as my/our surveyor *<and if appropriate add 'or as an agreed surveyor'>* .

Signed: ..... Date: .....

Print name: .....

**Note:** If signed by the surveyor, insert 'authorised to sign on behalf of' and the name(s) of the building owner. Duplicate signature, date and name lines as necessary for joint owners signatures.

# 6 Acknowledgment of notice of adjacent excavation

---

## **Party Wall etc. Act 1996, section 6**

To be completed and returned to the building owner or the surveyor named on the notice

I/We <insert name(s) of the adjoining owner(s)>

of <insert adjoining owner's main postal address>

having received notice served by

<insert name(s) of the building owner(s)>

of <insert building owner's main postal address>

in respect of proposed works at

<insert address of the building owner's property to be worked on>

which adjoins my/our premises known as

<insert address of property adjacent to the works>

and in relation to the works proposed under section 6 (please delete two of the below options marked \* as appropriate)

\* hereby consent to the above works **OR**

\* hereby dissent from the above works and, a dispute having arisen, concur in the appointment of <insert surveyor's name> as an agreed surveyor **OR**

\* hereby dissent from the above works and, a dispute having arisen, appoint <insert surveyor's name>

of <insert surveyor's practice and address>

as my/our surveyor.

Signed: ..... Date: .....

Print name: .....

**Note:** Duplicate signature, date and name lines as necessary for joint multiple owners.

# Appendix C: Example schedule of condition



# Example schedule of condition

The schedule of condition records the condition of relevant parts of an adjoining owner's property before the start of the building owner's works. It enables the surveyors, at a later date, to determine the extent of the building owner's liability for damage caused by the works.

It should be as detailed as necessary for its purpose, but should not extend to areas which are too remote to be damaged, or include irrelevant descriptions. It should, for example, include all signs of cracking and damp damage within 1–2m of the works, or the whole of the room adjacent to the party wall and within a greater distance, if the case warrants it. Often the simple description of an area of surface plaster crazing will be more useful than a detailed description of every hairline crack forming it. However, it should generally not include matters such as paint colours, descriptions of door furniture, type of carpeting, etc.

It is common for it to be written in the 'Item, Description, Condition' format, and to begin on the top floor. Photographs are sometimes used. However, these can be time consuming and costly in reproduction. Furthermore, although capable of showing a general state of dilapidation, they generally provide little assistance in determining whether, for example, a hairline crack has worsened. Sketches may also be useful in identifying areas of damage or patterns of cracking.

The cover sheet will state that it is a schedule of condition of those parts of the property in question (identified by its address) close or adjacent to the site (again identified by its address). It will give the date on which the schedule was taken and may include reference to the name(s) of the appointed surveyor(s). It will then adopt a format similar to that in the following example.

External		
Item	Description	Condition
<b>Front elevation</b>		
Walls	<ul style="list-style-type: none"> <li>Elevation constructed in brick work, decorated with masonry paint</li> <li>Rendered parapet at high level with lead cappings</li> <li>Timber bresummer at head of ground floor windows and doors, painted</li> </ul>	<ul style="list-style-type: none"> <li>Some unevenness to render at high level parapet beneath paint finish</li> <li>One split in paint adjacent to party wall line at high level</li> <li>Otherwise, paint all intact and clean</li> </ul>
Joinery	<ul style="list-style-type: none"> <li>Timber windows, garage doors and front door decorated with gloss paint</li> </ul>	<ul style="list-style-type: none"> <li>Paint in slightly weathered condition with flaking paint to bottom rails of windows</li> <li>All glazing intact</li> <li>Paint generally flaking to base of garage doors and some flaking paint to dark painted plinth at base of wall</li> </ul>
Rear roof slope (as viewed from adjoining property)	<ul style="list-style-type: none"> <li>Pitched roof clad in Welsh slates</li> <li>Lead flashings to brick parapet</li> </ul>	<ul style="list-style-type: none"> <li>On half of roof slope closer to No. 7 party wall two slopes have chipped corners and one has slipped</li> <li>Flashing on party wall curled on bottom edge and not dressed flat to slates</li> </ul>

Internal		
Item	Description	Condition
<b>First floor</b>		
<b>Rear kitchen</b>		
Ceiling	<ul style="list-style-type: none"> <li>Plasterboard ceiling decorated with emulsion paint</li> </ul>	<ul style="list-style-type: none"> <li>Ceiling slopes down to west</li> </ul>
Walls	<ul style="list-style-type: none"> <li>Plastered walls decorated with emulsion paint</li> <li>Tiled splashback around kitchen units</li> <li>Fitted floor units on north and east walls and fitted wall units on party wall</li> </ul>	<ul style="list-style-type: none"> <li>Open joint at junction of west wall and ceiling continues down north-west corner and through tile grout to top of cable penetrating behind tiles</li> <li>Crack hairline: fine hairline crack in south-west corner runs down from ceiling to level with head of door</li> <li>In south-east corner, hairline crack, partially staggered at high level, running down from ceiling to behind microwave on shelf bracket</li> <li>Adjacent to this, horizontal hairline crack to underside of projecting timber joist running from south-east corner over top of cupboards, where it disappears from view</li> </ul>
Floor	<ul style="list-style-type: none"> <li>Timber floor laid with laminate flooring</li> </ul>	<ul style="list-style-type: none"> <li>Floor slopes down towards south-west with creaky floor-boards in centre but floor otherwise sound and laminate flooring tight jointed</li> </ul>
Window	<ul style="list-style-type: none"> <li>Timber casement window decorated with gloss paint</li> </ul>	<ul style="list-style-type: none"> <li>Left casement operates correctly, right casement catches when opening</li> <li>All glazing intact</li> <li>Fine open joint to junction of window sill and window frame extending from left side of sill to just beyond left casement</li> </ul>
Door	<ul style="list-style-type: none"> <li>Timber fully glazed door decorated with gloss paint</li> </ul>	<ul style="list-style-type: none"> <li>Door slightly warped protruding into room at foot, preventing closing home</li> </ul>
<b>Front Bedroom</b>		
Ceiling	<ul style="list-style-type: none"> <li>Lath and plaster ceiling decorated with emulsion paint.</li> </ul>	<ul style="list-style-type: none"> <li>Ceiling generally uneven and slightly bowed; bowing particularly noticeable sloping down from front elevation</li> <li>Hairline crack over head of left window runs into ceiling for one metre; where crack terminates, evidence of patch repair in plaster</li> <li>Approximately 500mm to west of this is one popped nailhead</li> </ul>

Ceiling (continued)		<ul style="list-style-type: none"> <li>• Evidence of previous crack extending from the one that extends from the window that previously ran to the north wall since filled and decorated</li> <li>• Areas of unevenness on line approximately 500mm from north wall and one re-opened split 10mm long</li> <li>• Open hairline joints in cornice in corners of room and over door to adjoining bedroom on west side</li> </ul>
Walls	<ul style="list-style-type: none"> <li>• Plastered walls decorated with wallpaper</li> </ul>	<ul style="list-style-type: none"> <li>• No defects identified</li> </ul>
Floor	<ul style="list-style-type: none"> <li>• Timber floor laid with fitted carpet</li> </ul>	<ul style="list-style-type: none"> <li>• Floor slopes down to north – otherwise floor sound</li> </ul>
Windows	<ul style="list-style-type: none"> <li>• Timber double hung sliding sash window and pair of French doors, all decorated with gloss paint</li> </ul>	<ul style="list-style-type: none"> <li>• Window operates correctly</li> <li>• Paint flaking to bottom rail of lower sash and paint flaking to top surface of external sills</li> <li>• All glazing intact</li> </ul>
Door	<ul style="list-style-type: none"> <li>• Timber flush door decorated with gloss paint</li> </ul>	<ul style="list-style-type: none"> <li>• Door very slightly warped protruding into room at foot preventing latch closing home</li> </ul>





# Appendix D: Draft award



# Draft award

---

AN AWARD under the provisions of the *Party Wall etc. Act 1996*.

WHEREAS <insert name of building owner> of <insert main postal address of building owner>  
<insert address of building owner's property to be worked on> ('the building owner') is an owner within the meaning of the *Party Wall etc. Act 1996* ('the Act') of the premises known as <insert address of building owner's property to be worked on> ('the building owner's property').

AND <insert name of adjoining owner> of <insert main postal address of adjoining owner>  
<insert address of adjoining owner's property adjacent to the works> ('the adjoining owner') is an owner within the meaning of the Act of the premises known as <insert address of adjoining owner's property adjacent to the works> ('the adjoining owner's property').

AND on the <insert date of notice> the building owner served notice(s) on the adjoining owner under <insert sections of Act under which notice was served> of the Act of its intention to execute the building works described therein between the building owner's property and the adjoining owner's property (the two properties).

AND a dispute or deemed dispute has arisen between the building owner and the adjoining owner within the meaning of the Act.

AND the building owner has appointed <insert name of surveyor> of <insert surveyor's practice and address> as building owner's surveyor and the adjoining owner has appointed <insert name of surveyor> of <insert surveyor's practice and address> as adjoining owner's surveyor.

AND the building owner's surveyor and the adjoining owner's surveyor (the two surveyors) have selected <insert name of surveyor> of <insert surveyor's practice and address> to act as third surveyor in accordance with the provisions of the Act.

In the event of the third surveyor being unable or unwilling to act and their being unable jointly to agree upon a substitute, another third surveyor shall be appointed by the appointing officer of the relevant local authority in accordance with section 10(8) of the above Act.

It is a requirement of the Act that the three surveyors or any two of them, or in the event of no two of them being in agreement the third surveyor, shall settle by award all or any matter which is connected with any work to which the Act relates and which is in dispute between the building owner and the adjoining owner including: the right to execute the work, the time and manner of executing the work, and any other matter arising out of the dispute including the cost of obtaining and making this award.

This award and its conditions relate only to the works described in clause 2 of this award and do not relate to other works outside the scope of the Act.

Any agreement or acceptance made by either surveyor in this award or subsequently during works on site shall not be taken to imply any responsibility by them or their appointed technical delegates for any structural or any other insufficiency in any part of the works whether existing or executed.

That nothing in this award shall be held as conferring, admitting or affecting any easement of light or other easement in or relating to the party wall.

The said premises having been inspected, we the undersigned, being the appointed surveyors, and having considered the proposals made by the building owner and any other relevant matters brought to our attention but without prejudice to any other rights of the parties or of any other persons DO HEREBY MAKE THIS OUR AWARD.

**Note:** Surveyors should ensure that all clauses in an award are relevant to the works under consideration. Suggested terms should be amended as appropriate, clauses not applicable should be omitted and additional clauses required to suit the specific work should be inserted as necessary.

1. <delete as appropriate>

- \*(a) That the <insert 'wall' or 'structure'> separating the two properties is a <insert 'party wall', 'party fence wall' or 'party structure'> within the meaning of the Act.
- \*(a) That the adjoining owner's property is an independent building standing close to or adjoining the building owner's property, within the meaning of the Act.
- (b) That the <insert 'party wall', 'party fence wall' or 'party structure'> and the adjoining owner's building as described in the attached schedule of condition is sufficient for the present purposes of the adjoining owner.
- (c) A schedule of condition dated <insert date the schedule was recorded> signed by us, the said two surveyors, is attached hereto as a record of fact and relates to the adjacent parts of the adjoining owner's premises prior to the execution of the said work so far as can be ascertained without opening up or disturbing the structure or finishings.
- (d) That the drawing(s) numbered <insert all drawing numbers> and attached hereto form part of this award.

**Note:** Repeat this clause for method statement, programmes, calculations, etc., as required.

2. That after service of the signed award the building owner shall be at liberty, but under no obligation, to carry out the following works:

**Note:** It would be helpful for the list of works to follow the sequencing of the works on site as closely as possible.

- (a) \_\_\_\_\_
- (b) \_\_\_\_\_
- (c) \_\_\_\_\_

3. That no deviation from the works shall be made without the prior written agreement of the owners, or surveyors acting on their behalf and with their express authority, or in the event of a dispute determined by the appointed surveyors in accordance with section 10.

4. That if the building owner commences the works, the building owner shall:

- (a) Execute the whole of the works and do so at the sole cost of the building owner.
- (b) Take all reasonable precautions and provide all necessary support to retain the land and buildings comprised within the adjoining owner's property.

- (c) Provide temporary weathering in the form of heavy duty felt secured by timber battens at 1m centres both horizontally and vertically to those parts of the adjoining owner's property/party wall exposed as a result of the works and maintain this until permanent weathering has been provided unless otherwise agreed in writing by the surveyors.
  - (d) Make good all structural or decorative damage to the adjoining owner's property occasioned by the works in materials to match the existing fabric and finishes, to the reasonable satisfaction of the two surveyors, with such making good to be executed upon completion of the works, or at any earlier time deemed appropriate by the two surveyors. If so required by the adjoining owner, make payment in lieu of carrying out the work to make the damage good, with such sum to be agreed between the owners or determined by the surveyors.
  - (e) Compensate any adjoining owner and any adjoining occupier for any loss or damage which may result to any of them by reason of any work executed in pursuance of this Act.
  - (f) Permit the adjoining owner's surveyor to have access to the relevant parts of the building owner's property at all reasonable times during, and to inspect, the progress of the works.
  - (g) Carry out the whole of the works so far as practicable from the building owner's land. Where access to the adjoining owner's property is required, reasonable notice shall be given in accordance with section 8 of the Act. In the event of the building owner wishing to carry out the works from, or to erect scaffolding on or over the adjoining owner's property for the purpose of works, details thereof shall first be submitted to and approved by the surveyors and such approval shall be subject to such conditions as the surveyors may agree.
  - (h) Restrict noisy works to which this award relates to the <insert 'party wall' or 'party structure' or 'adjoining owner's premises'> to between the hours of <insert appropriate hours and days> .
  - (i) Remove any scaffolding or screens from the adjoining owner's property and land as soon as possible.
  - (j) Clear away any dust and debris from time to time as necessary, or when agreed by the surveyors.
5. That the building owner's surveyor shall be permitted access to the relevant parts of the adjoining owner's property from time to time during, and to inspect, the progress of the works at reasonable times and after giving reasonable notice.
  6. That the whole of the works shall be executed in accordance with the Building Regulations, and all requirements and by-laws of statutory authorities where these apply and shall be executed in a proper and workman-like manner in sound and suitable materials in accordance with the terms of this award to the reasonable satisfaction of the surveyors.
  7. That the works shall be carried through with reasonable expedition after commencement and so as to avoid unnecessary inconvenience to the adjoining owner or occupiers.
  8. That a copy of this award shall be provided for the adjoining owner's surveyor.
  9. That the building owner shall upon completion of the works provide to the adjoining owner a set of the 'as built' drawings of the works insofar as they may be different from the drawings forming part of this award, at the sole cost of the building owner.

**Note:** This only relates to works carried out under section 6 of the Act).

10. That the building owner shall immediately on the service of this award pay the adjoining owner's costs by way of their surveyor's fees in the sum of £ <insert net figure> plus VAT (£ <insert gross figure> ) in connection with the obtaining and making of this award, and <insert number of agreed site visits> subsequent inspection(s) of the works. In the event of damage being caused or other contingencies or variations arising, a further fee shall be payable at a rate of £ <insert agreed time charge> per hour plus VAT.

**Note:** Insert additional similar clause(s) for costs by way of engineers' fees and/or other consultants' fees or costs. Insert additional clause(s) in respect of other monetary provisions such as 'due proportion', 'fair allowance', 'payments in lieu', 'compensation', etc.

11. That the said surveyors reserve the right to make and issue any further award(s) that may be necessary, as provided in the Act.

12. That the building owner's authority to carry out the works under this award is conditional upon the works being commenced within <insert time period> .

13. That either of the parties to the dispute may within 14 days from the date this award is served upon them appeal to the county court against this award.

IN WITNESS we have set out hands this <insert date> day of <insert month and year> .

**Note:** The second surveyor signing the award should date it. Some meaningful part of the award should appear on the signature page.

.....  
Building owner's surveyor

WITNESS .....

Name: .....

Address: .....

Occupation: .....

.....  
Adjoining owner's surveyor

WITNESS .....

Name: .....

Address: .....

Occupation: .....



# Further reading

---

Anstey, J., and North, G., *Anstey's Party Walls* (6th edition), RICS Books, Coventry 2005

Bickford-Smith, S., and Sydenham, C., *Party Walls: Law and Practice* (3rd edition), Jordan Publishing Ltd, Bristol 2009

Chynoweth, P., *The Party Wall Casebook*, Blackwell Publishing 2003

Pyramus & Thisbe Club, *The Party Wall Act Explained: A Commentary on the Party Wall etc. Act 1996* (the 'Green Book') (2nd edition), the Pyramus & Thisbe Club 1996

Redler, A., *Practical Neighbour Law Handbook*, RICS Books, Coventry 2006

Hannaford, S., and Stephens, J., *Case in Point – Party Walls*, RICS Books, Coventry 2004

## Useful websites

Pyramus and Thisbe Club: [www.partywalls.org.uk](http://www.partywalls.org.uk)

RICS Boundaries and Party Walls Working Group: [www.rics.org](http://www.rics.org)

# Party wall legislation and procedure

6th edition, guidance note

The *Party Walls etc. Act* 1996 provides a framework for dealing with the complex and often expensive disputes between property owners over the repair and maintenance of a party wall. Providing clear guidance on this Act is *Party wall legislation and procedure*, which is essential reading for chartered surveyors who accept instructions where the *Party Wall etc. Act* 1996 is relevant. Features of this guidance note include:

- various stages involved in party wall work arranged chronologically;
- guidance for surveyors when acting for clients in the early stages of party wall;
- procedure and those appointed to administer the Act's dispute resolution mechanism;
- relevant draft forms and precedents; and
- a clear presentation of guidance to meet the requirements of the busy professional.

This edition of *Party wall legislation and procedure* is a complete rewrite of the previous edition, providing guidance for surveyors working in circumstances where the *Party Walls etc. Act* 1996 will apply as well as the procedures to be followed.

It examines in detail the key issues, namely:

- the nature and purpose of the *Party Wall etc. Act* 1996;
- advice to be given to clients on the application of the Act;
- service of notices;
- acceptance of appointments under the Act;
- powers and duties of appointed surveyors;
- surveyors' role in preparing primary award;
- surveyors' role subsequent to publication of primary award; and
- challenges to surveyors' decisions.



**RICS**

the mark of  
property  
professionalism  
worldwide

[rics.org/standards](https://rics.org/standards)

